



ME-160

# Mechanical Engineering Drawing

## Sectional Views (with Ribs)

**Prepared By:**

Musanna Galib

Md. Rakib Hossain

**Course Teachers:**

Musanna Galib

Saif Al-Afsan Shamim

Abdul Aziz Shuvo

# Parts should not be sectioned !

- When the cutting plane passes through **Thin features** such as **rib** or a web, shafts, keys & splines, nuts, bolts & rivets - such parts are not sectioned .

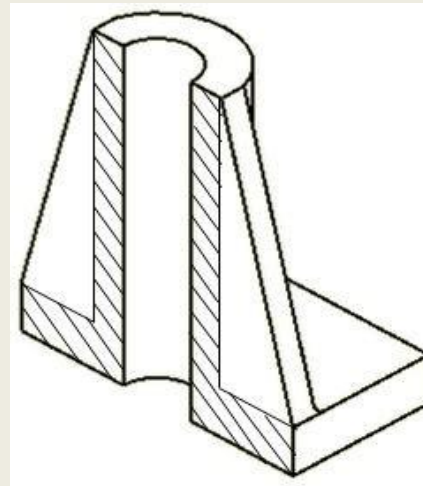
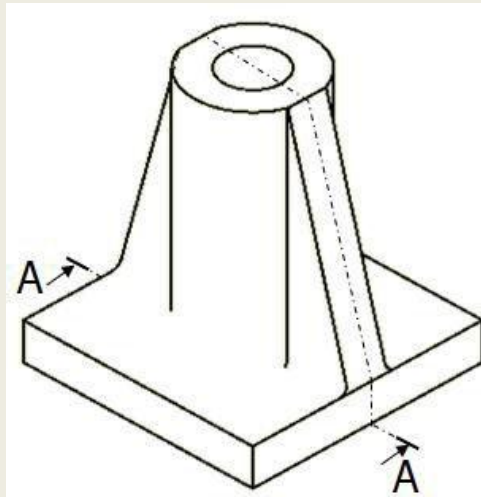

# Conventional Practice

- Omit the section lines on the sectional view if the cutting plane is passed **flat wise** through (for Rib, Web, Lug )

**Let's See an Example !**

# Example:

## Web: Flat Wise Cut

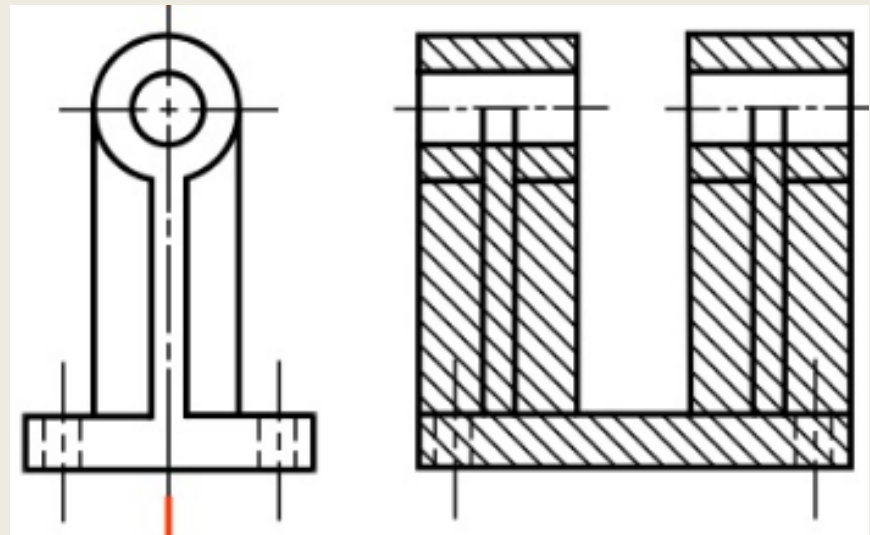
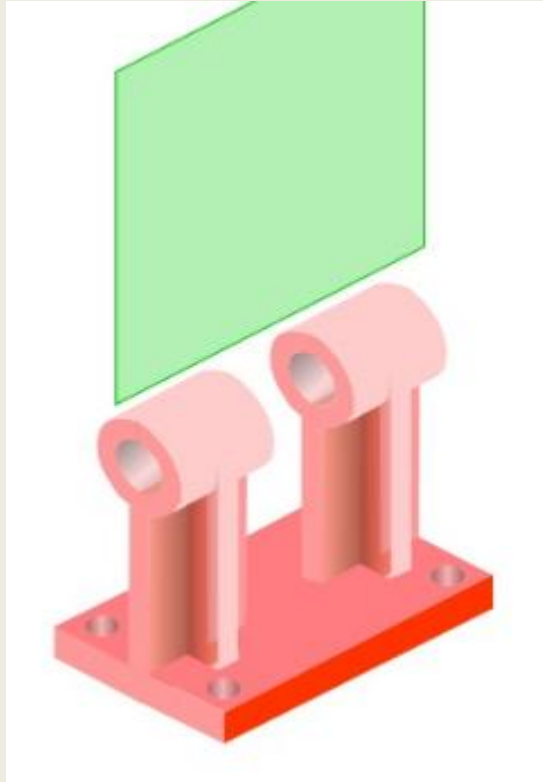

# Example:

## Web: Cross Wise Cut

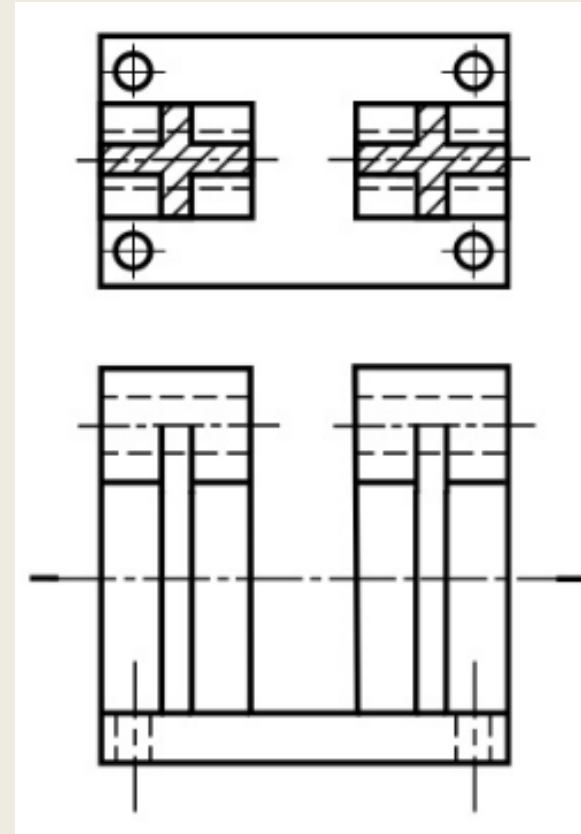
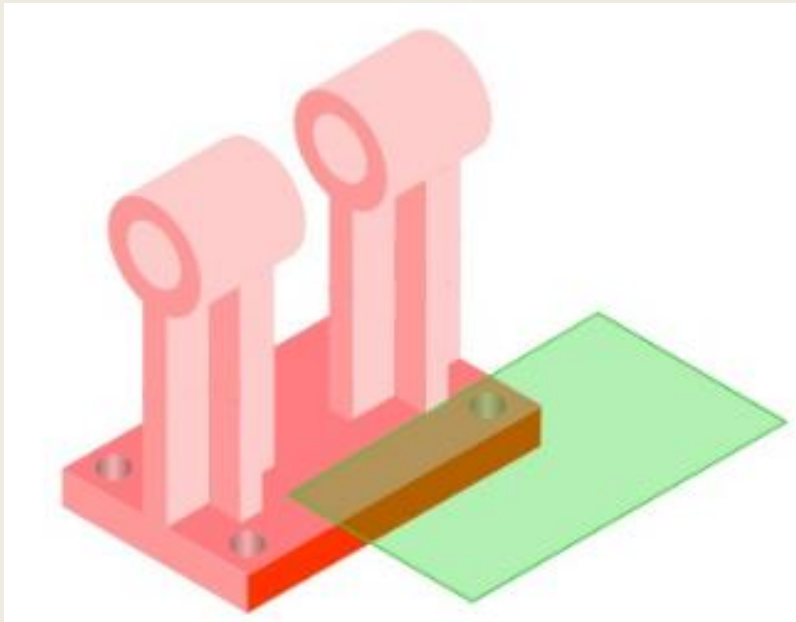

# What is RIB ?

- Ribs and webs are often used in molds and castings. In plastic parts, they are commonly used to create **rigidity** and to prevent **warping** (buckling).

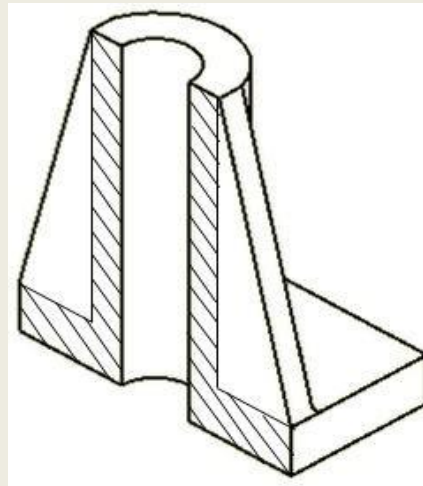
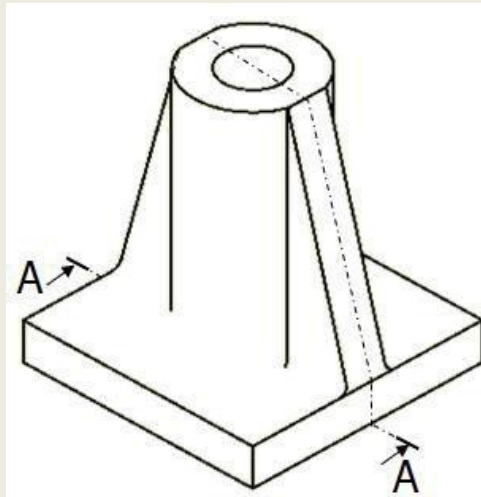

# What is Web ?

- Ribs and webs are often used in molds and castings. In plastic parts, they are commonly used to create **rigidity** and to prevent **warping** (buckling).

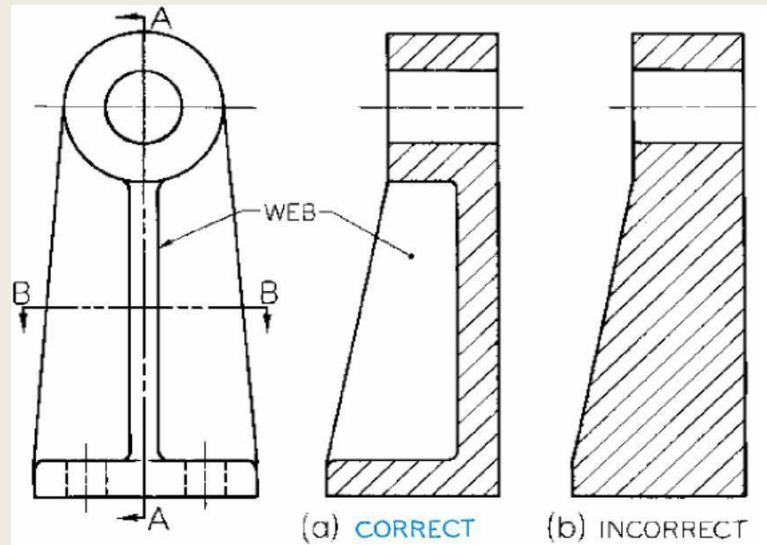

# What is Lug ?

- Lug is an ear which is built as portion of an object for attachment .

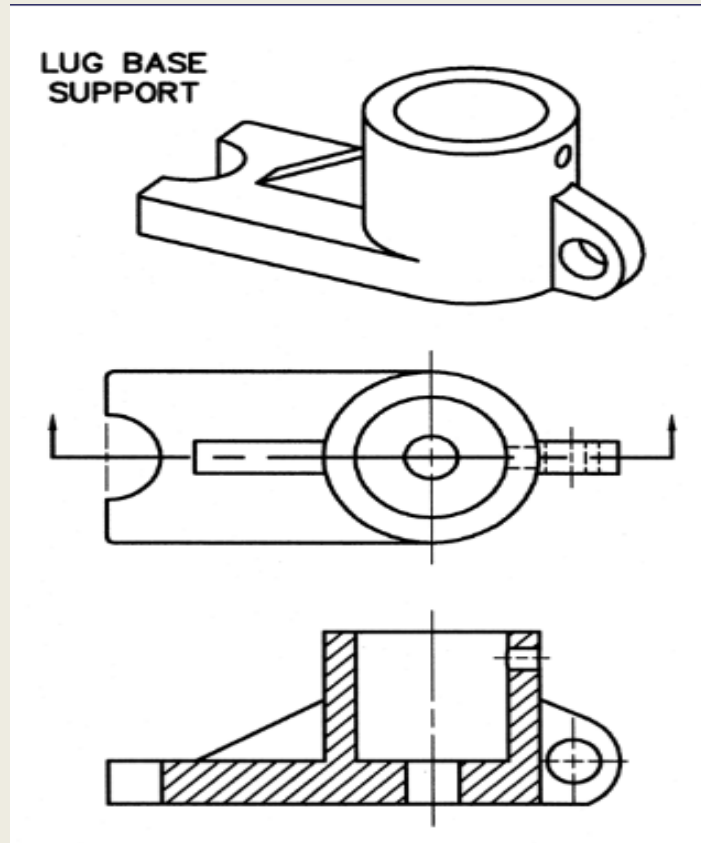



# Nuts, Bolts and shafts

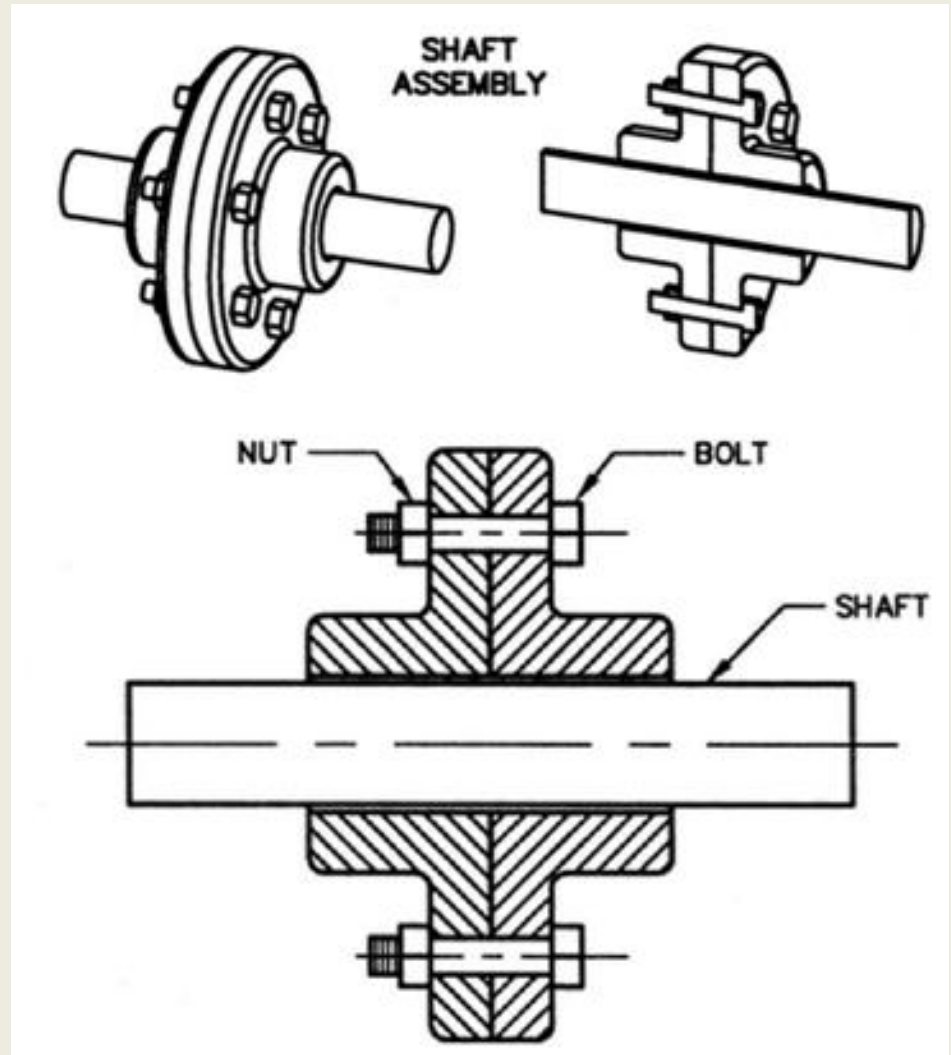
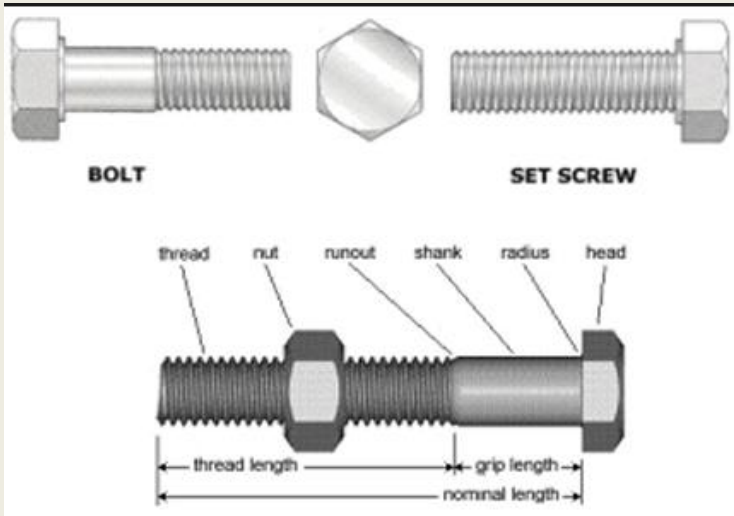

# Hatching

## Section Lining

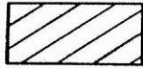

Cast Iron

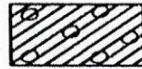

Sound  
Insulation

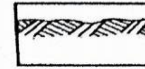

Earth



Steel

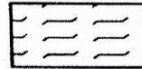

Cork, Felt,  
Leather & Fiber



Rock



Bronze, Brass,  
Copper and  
Compositions



Fire Brick  
and Refractory  
Materials

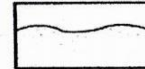

Sand



White Metal,  
Zinc, Lead,  
Babbit and  
Alloys

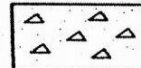

Concrete

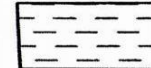

Water &  
Other Liquids



Magnesium,  
Aluminum



Marble, Slate,  
Glass, Porcelain



Electric  
Windings,  
Electromagnets etc.



Rubber, Plastic,  
Electrical Insulation

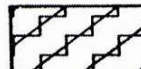

Thermal  
Insulation



Wood

Symbols for Section Lining

# Lines

- Object Line : 100% thick
- Hidden Line: 50% thick
- Dimension, Extension Line: 25% thick
- Center Line : 50% thick
- Cutting Plane Line : 125% thick
- Hatchet line :25% thick

**Object Line**

**Thickness: 100 %**

**Hidden Line**

**Thickness: 50 %**

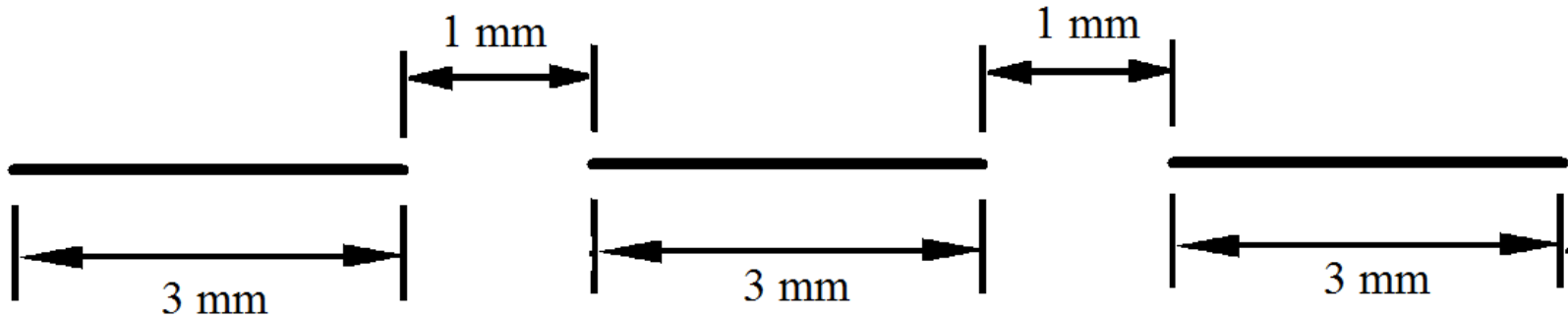

**Center Line**

**Thickness: 50 %**

Dimension and  
Extension Lines

Light  
3.000

Thickness: 25 %

Thickness: 125 %

Section Line

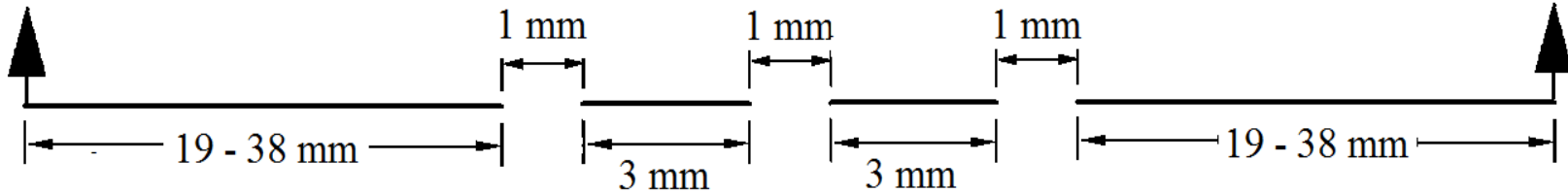

**N.B.: All Percentages are with respect to the object line**

# First Problem

- **Corrections:** fillet radius is given 5 instead of 10, width 76 instead of 70

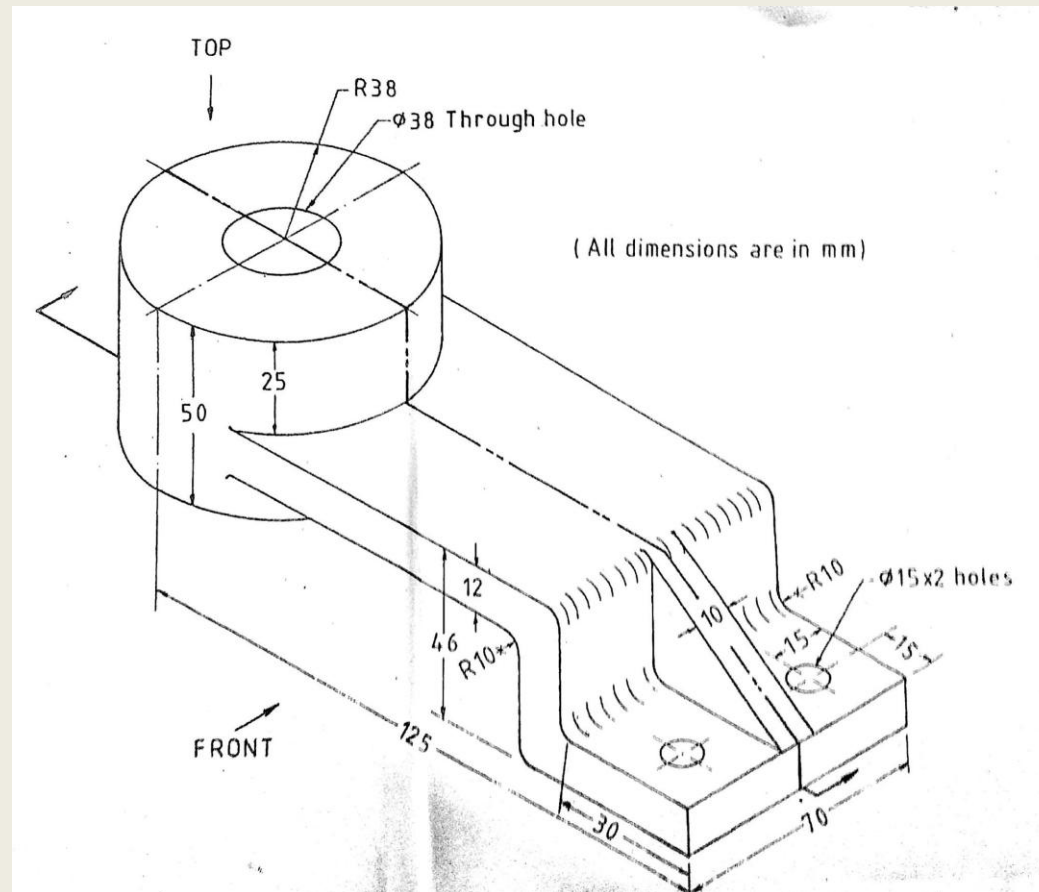

# First Problem

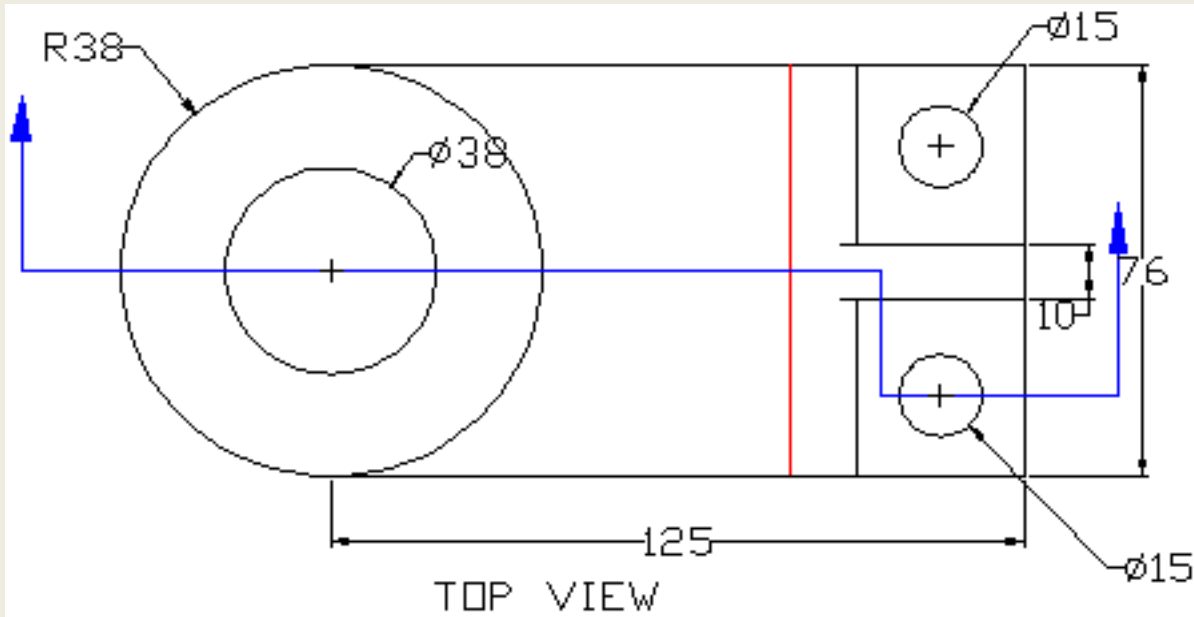

- CUTTING PLANE
- HIDDEN LINE
- CENTER LINE

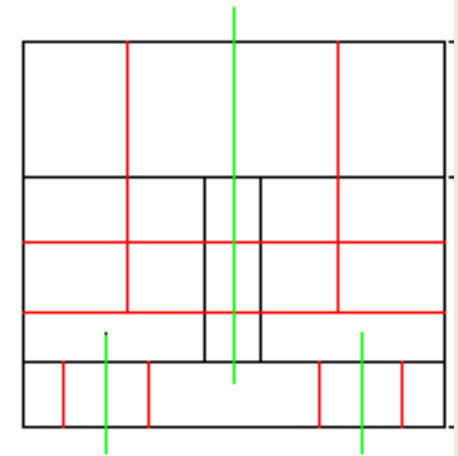
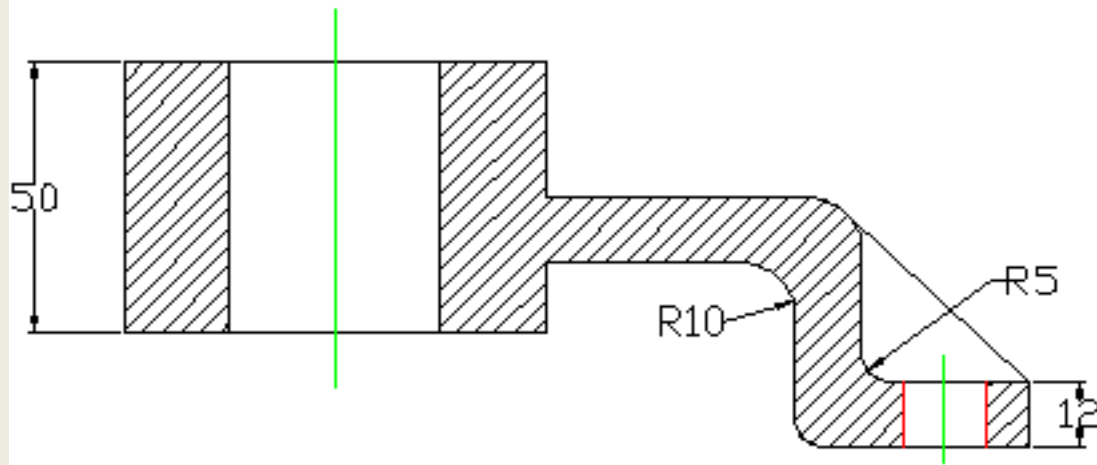

**Persist Until Succeed !!!**